

Ready? Set? Play!

Sound advice for getting started on your instrument

YOUR INSTRUMENT—KEYBOARD (MALLET) PERCUSSION

The keyboard percussion family includes orchestra bells, xylophone, marimba, vibraphone and chimes. Each instrument is arranged chromatically in two rows similar to a piano keyboard. Because of the different materials used, each instrument has a unique sound. Since few of the keyboard percussion instruments have been standardized in range, the most practical ranges for school use are listed below.

ORCHESTRA BELLS (also called Bells or Glockenspiel)

Although some student bell kits are $1\frac{1}{2}$ octaves, the standard range is $2\frac{1}{2}$ octaves. The instrument is played with brass, plastic or hard-rubber mallets.

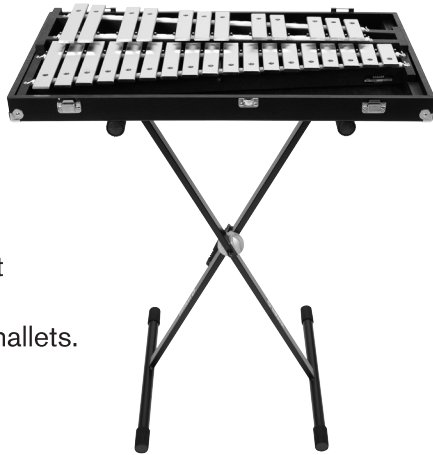

MARIMBA

The most practical range is either a 4 or $4\frac{1}{3}$ octave instrument. It is played with yarn, cord-wound or rubber mallets. Do not use wood, plastic or metal mallets!



XYLOPHONE

The most practical range is either a 3 or $3\frac{1}{2}$ octave instrument. It is played with wood or hard-rubber mallets. Do not use metal mallets!



CHIMES

(also called Tubular Bells)
The standard range for this instrument is $1\frac{1}{2}$ octaves. It is played by striking the ridge of the cap at the top of each tube with a hammer-shaped mallet made of rawhide. A foot-operated damper pedal controls the sustain.

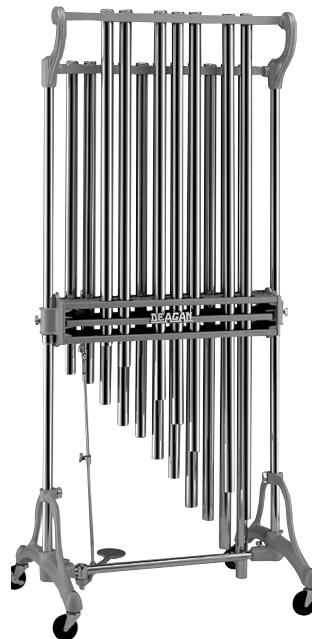

VIBRAPHONE (also called Vibraharp)

The standard range for this instrument is 3 octaves. It is played with yarn and cord-wound mallets. Do not use brass mallets! A foot-operated damper pedal controls the sustain.



CARE AND MAINTENANCE

- Use a cloth to keep your mallet instruments clean. The use of furniture polish on wooden bars should be avoided as it will leave a residue. When not in use, the instruments should be covered.
- Mallets should be stored in a bag with your sticks.
- Other than mallets, do not set anything on top of a keyboard instrument. It is not a table!

Please refer to the Sound Innovations DVD for detailed instructions and demonstrations of assembly, disassembly and maintenance of your instrument. Whenever you see this icon , refer to your DVD for further demonstrations.

Ready? Set? Play!

Sound advice for getting started on your instrument

YOUR INSTRUMENT—THE SNARE DRUM, BASS DRUM AND ACCESSORY PERCUSSION

The Snare Drum & Stand

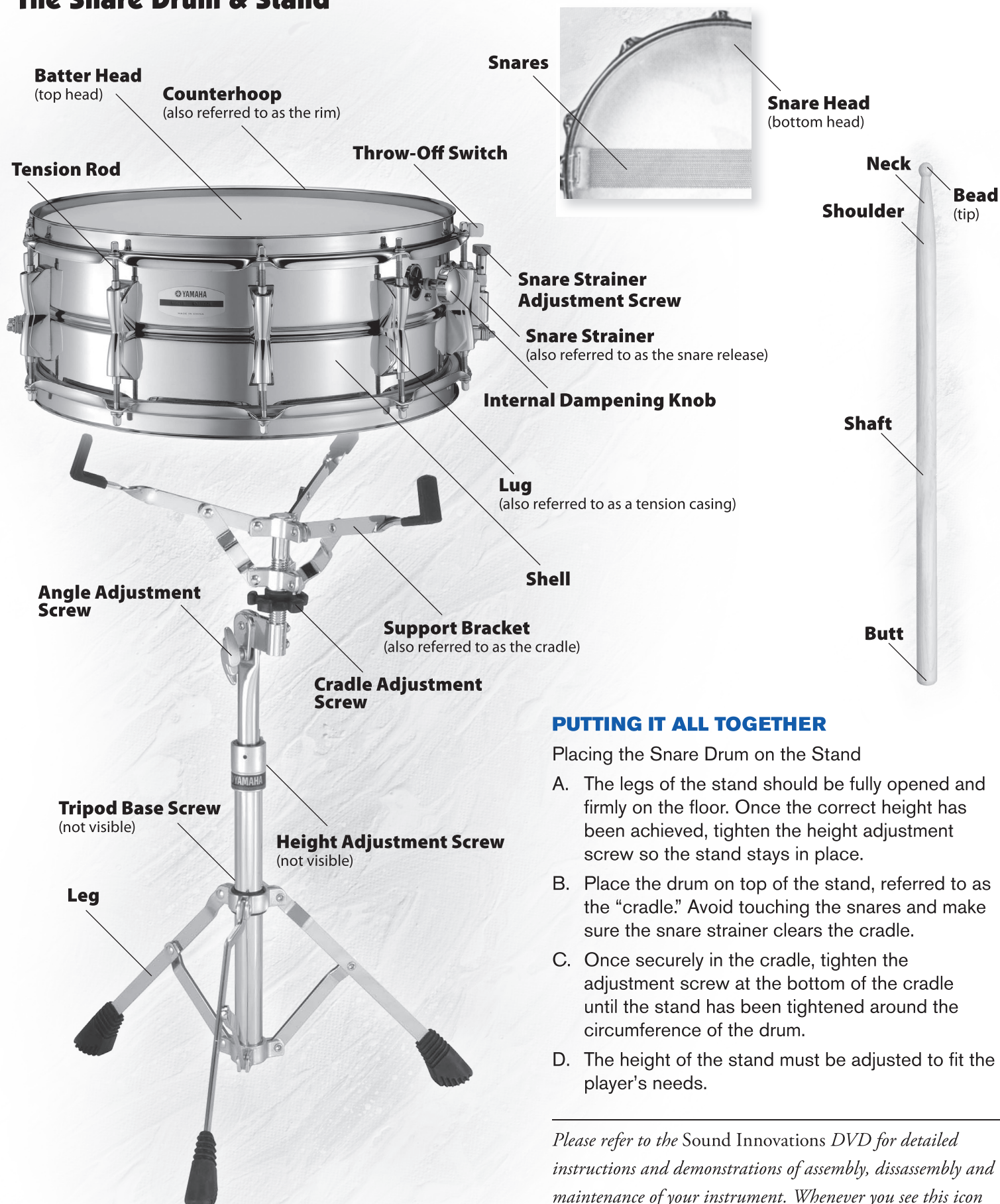

PUTTING IT ALL TOGETHER

Placing the Snare Drum on the Stand



- The legs of the stand should be fully opened and firmly on the floor. Once the correct height has been achieved, tighten the height adjustment screw so the stand stays in place.
- Place the drum on top of the stand, referred to as the "cradle." Avoid touching the snares and make sure the snare strainer clears the cradle.
- Once securely in the cradle, tighten the adjustment screw at the bottom of the cradle until the stand has been tightened around the circumference of the drum.
- The height of the stand must be adjusted to fit the player's needs.

Please refer to the Sound Innovations DVD for detailed instructions and demonstrations of assembly, disassembly and maintenance of your instrument. Whenever you see this icon , refer to your DVD for further demonstrations.

Level 3: Sound Musicianship

SOUNDS NEW! Introducing the new note, Ab.

77

Ab   

The new key signature of **E-FLAT MAJOR** tells you that all B's, E's and A's are flat.



STYLE MARKINGS are sometimes used instead of tempo markings to help musicians understand the feeling the composer would like the music to convey.

WAY UP HIGH—Before you play, circle all the notes affected by the key signature. Discuss ways in which you can make this sound “sweet.”

78

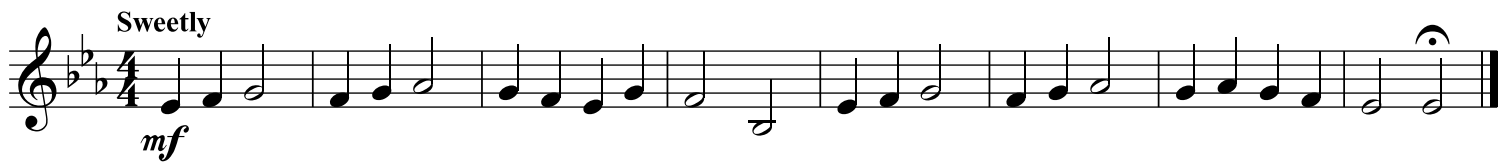
Sweetly
mf 

BINGO—Before playing, discuss ways in which you can make this sound “light.” Name the key.

American Folk Song

79

Lightly
mp 

1ST AND 2ND ENDINGS: Play the 1st ending the first time through. Repeat the music, but skip over the 1st ending on the repeat and play the 2nd ending instead.

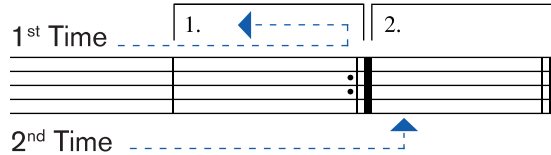

BUFFALO GALS—Since this is played with spirit, the tempo should be energetic! Watch the 1st and 2nd endings.

American Traditional

80

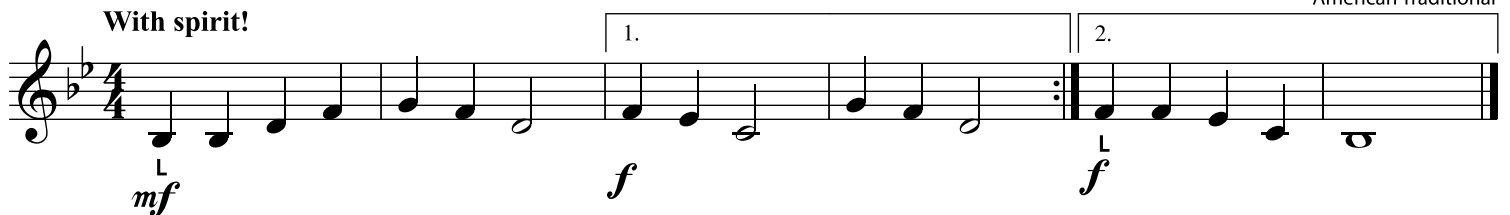
With spirit!
mf 

MUSETTE—Here is a tune to play just for fun!

Johann Sebastian Bach

81

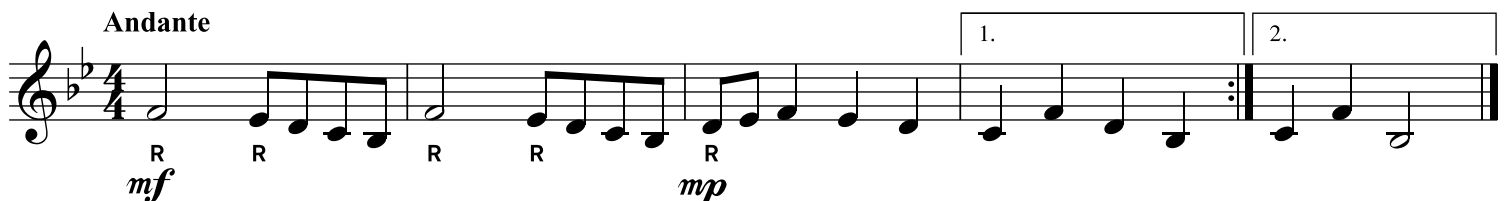
Andante
mf 

Level 3: Sound Musicianship

SOUNDS NEW!

77 **Tamb.**

STYLE MARKINGS are sometimes used instead of tempo markings to help musicians understand the feeling the composer would like the music to convey.



The most common type of **TAMBOURINE ROLL** is the shake roll. Hold the tambourine in either hand and shake it by rapidly rotating the wrist back and forth. Most rolls start and stop with a strike on the head.

WAY UP HIGH—Before playing, discuss ways in which you can make this sound “sweet.”

Sweetly

78 **Tri.**

BINGO—Before playing, discuss ways in which you can make this sound “light.”

Lightly

79 **Tamb.**

American Folk Song

1ST AND 2ND ENDINGS: Play the 1st ending the first time through. Repeat the music, but skip over the 1st ending on the repeat and play the 2nd ending instead.

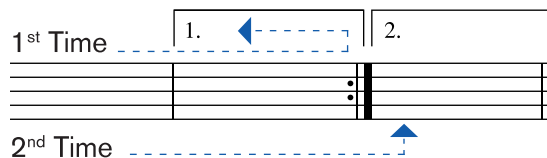

BUFFALO GALS—Since this is played with spirit, the tempo should be energetic! Watch the 1st and 2nd endings.

With spirit!

(Paradiddle)

American Traditional

80

MUSETTE—Here is a tune to play just for fun!

Andante

Johann Sebastian Bach

81

Scales, Arpeggios, Warm-Up Chorales and Etudes***Key of F Major****SCALE & ARPEGGIO**

184

CHORALE IN CONCERT F MAJOR—Full band arrangement.

185

SCALE ETUDE

186

INTERVAL ETUDE

187

Key of Bb Major**SCALE & ARPEGGIO**

188

CHORALE IN CONCERT Bb MAJOR—Full band arrangement.

189

SCALE ETUDE

190

INTERVAL ETUDE

191

*Scale and Etude exercises may be played with other instruments but are not always in unison.

Scales, Arpeggios, Warm-Up Chorales and Etudes*

Key of F Major

SCALE & ARPEGGIO

184 

CHORALE IN CONCERT F MAJOR—Full band arrangement.

185 

SCALE ETUDE

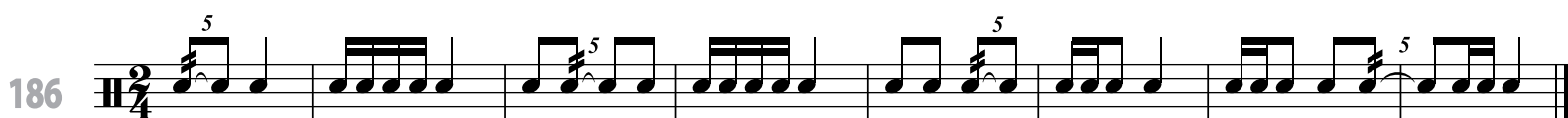
186 

INTERVAL ETUDE

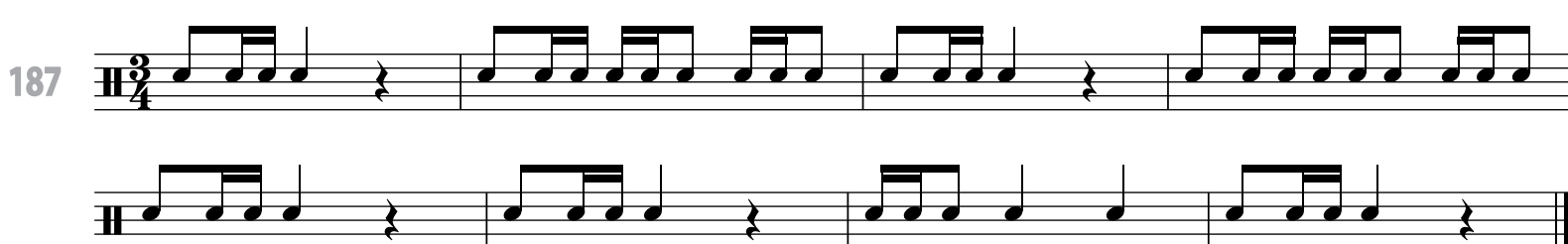
187 

Key of B♭ Major

SCALE & ARPEGGIO

188 

CHORALE IN CONCERT B♭ MAJOR—Full band arrangement.

189 

SCALE ETUDE

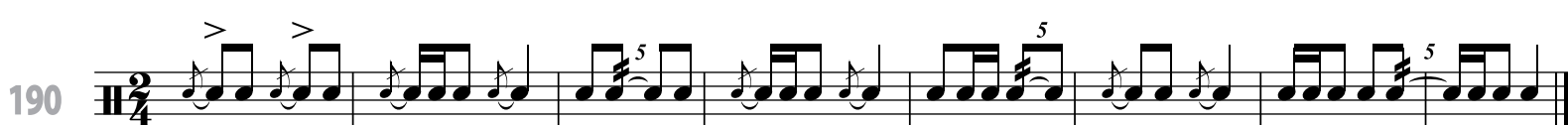
190 

INTERVAL ETUDE

191 

*Scale and Etude exercises may be played with other instruments but are not always in unison.